

Art.	Pag.	Art.	Pag.	Art.	Pag.
D.1	34	D.141	42	D.222	66
D.2	34	D.142	49	D.222 B	66
D.3	34	D.143	49	D.223	66
D.4	34	D.144	49	D.224	67
D.13	34	D.145	43	D.224 B	67
D.14	34	D.146	43	D.225	67
D.19	35	D.147	43	D.226	67
D.20	35	D.148	43	D.226 B	67
D.37	35	D.149	50	D.227	67
D.38	35	D.150	50	D.228	73
D.39	35	D.151	51	D.229	73
D.40	35	D.152	51	D.230	73
D.45	38	D.153	51	D.231	73
D.46	38	D.154	51	D.232	70
D.53	35	D.155	50	D.233	70
D.54	35	D.156	50	D.234	70
D.63 F	38	D.157	54	D.235	70
D.63 M	38	D.158	54	D.236	70
D.63 SP	38	D.165	55	D.237	70
D.64	38	D.169	52	D.238	70
D.72	36	D.170	52	D.239	70
D.73A	36	D.171	54	D.240	74
D.73B	36	D.172	52	D.241	74
D.75	39	D.173	52		
D.75 - 06	39	D.181	55	D.1001	76
D.76	39	D.182	55	D.1002	78
D.76 - 03	39	D.183	54	D.1003	76
D.77	40	D.188	58	D.1007	76
D.78	40	D.189	58	D.1008-A	79
D.79	40	D.190	58	D.1008-B	79
D.80	41	D.195	56, 57	D.1009/A	82
D.83	40	D.196	56, 57	D.1009/B	82
D.84	41	D.197	56	D.1009/C	82
D.87	36	D.198	34	D.1010	76
D.88	36	D.199	50	D.1013	83
D.89	36	D.200	64	D.1014	83
D.90	36	D.200-B	64	D.1015	79
D.92	42	D.201	64	D.1016	79
D.93	42	D.201-B	64	D.1017	78
D.97	41	D.202	53	D.1018	78
D.98	41	D.203	53	D.1023	80
D.99	41	D.204	53	D.1024	80
D.100	42	D.205	39	D.1025	80
D.103	44	D.206	39	D.1026	81
D.104	44	D.207	60	D.1027	81
D.105	44	D.208	60	D.1028	82
D.106	45	D.209	60	D.1029	82
D.107	45	D.210	61	D.1030	83
D.109 SM	48	D.211	61	D.1031	83
D.122	46	D.212	61	D.1032	83
D.123	46	D.213	59	D.1033	83
D.124	46	D.214	59	D.1034	76
D.125	46	D.215	63	D.1035	76
D.126	42	D.216	63	D.1036	81
D.127 SM	48	D.217	63	D.1037	81
D.128 SM	48	D.218	63		
D.131	49	D.219	63		
D.132	47	D.220	66		
D.134	47	D.220 B	66		
D.135	47	D.221	66		

# INDICE

## INDEX



**GHIDINI**  
GIUSEPPE BOSCO

---

**Lumi e colonne**

Columns

Fûts - colonnes

Saeulen fuer Tischlampen

Varillas y pies

Kolumny i środkowe

części kolumn

Стволы и колонны



D.1



D.3



D.198



D.2



D.4



D.13



D.14

ARTICOLO ITEM	D	H	Ø INTERNO Ø INSIDE	Ø d
<b>D 1</b>	55	105	50	20
<b>D 2</b>	63	81	55	19
<b>D 3</b>	69	135	65	30
<b>D 4</b>	79	100	69	23
<b>D 13</b>	50	99	46	25
<b>D 14</b>	54	60	49	18
<b>D 198</b>	63	160	-	19



D.19



D.37



D.39



D.40



D.20



D.38



D.53



D.54

ARTICOLO ITEM	D	H	Ø INTERNO Ø INSIDE	Ø d
<b>D 19</b>	38	165	32	29
<b>D 20</b>	44	70	39	28
<b>D 37</b>	48	165	45	29
<b>D 38</b>	56	54	48	36
<b>D 39</b>	32	133	25	22
<b>D 40</b>	37	37	30	24
<b>D 53</b>	74	150	54	25
<b>D 54</b>	65	56	54	38



D.72



D.73/B

D.73/A



D.87



E.99



D.89



D.88



D.90

ARTICOLO ITEM	L	H	Ø SUP. Ø TOP	Ø INF. Ø BOTTOM
D 72	150	175	50	140
D 73/A	140	58		
D 73/B	51	5		
D 87	70	125	50	70
D 88	77	117	70	38
D 89	102	117	93	89
D 90	98	58	94	37
E 99	93	24	36	93

ARTICOLO ITEM	L	H	Ø SUP. Ø TOP	Ø INF. Ø BOTTOM
D 87	70	125	50	70
D 88	77	117	70	38
D 89	102	117	93	89
D 90	98	58	94	37
E 99	93	24	36	93
Z 77 torn	50	37	27	50

E.99



D.90

Z.77



D.87

D.88

E.99



D.89

D.90

# D



D.45

D.46



D.64



D.63F

D.63SP



D.63M

ARTICOLO ITEM	L	H	Ø SUP Ø TOP	Ø INF Ø BOTTOM
<b>D 45</b>	40	175	30	40
<b>D 46</b>	45	48	43	28
<b>D 63M</b>	100	106	49	100
<b>D 63F</b>	100	106	50	100
<b>D 63SP</b>	100	104	50	100
<b>D 64</b>	50	155	20	45

Articoli torniti / Machined items

ARTICOLO ITEM	L	H	Ø SUP Ø TOP	Ø INF Ø BOTTOM	FORI/FILETTI HOLES/THREADS
<b>D 75</b>	150	104	80	150	10x1
<b>D 75-6</b>	150	104	80	150	10x1 + 6 fori
<b>D 76</b>	90	76	50	90	10x1
<b>D 76-3</b>	90	76	50	90	10x1 + 3 fori
<b>D 205</b>	70	170	25	44	10,2
<b>D 206</b>	80	235	25	50	10,2

Articoli torniti / Machined items



D.75  
D.75-6



D.76  
D.76-3



D.205



D.206





D.79



D.78

ARTICOLO ITEM	L	H	Ø SUP Ø TOP	Ø INF Ø BOTTOM
<b>D 77</b>	57	70	23	21
<b>D 78</b>	37	55	20	15
<b>D 79</b>	50	60	24	30
<b>D 83</b>	71	87	35	40

Articoli torniti / Machined items



D.83



D.77



D.97



D.98

ARTICOLO ITEM	L	H	Ø SUP Ø TOP	Ø INF Ø BOTTOM
<b>D 80</b>	42	120	20	24
<b>D 84</b>	64	180	30	34
<b>D 97</b>	52	66	32	34/24
<b>D 98</b>	46	78	26	23
<b>D 99</b>	34	90	26	29/23

Articoli torniti / Machined items



D.99



D.80



D.84



D.92



D.100



D.126



D.93



D.141

ARTICOLO ITEM	L	H	Ø SUP Ø TOP	Ø INF Ø BOTTOM
<b>D 92</b>	38	145	14	24
<b>D 93</b>	55	170	30	25
<b>D 100</b>	43	161	22	28
<b>D 126</b>	39	185	24	25
<b>D 141</b>	31	142	16	25

Articoli torniti / Machined items

ARTICOLO ITEM	H	L	Ø SUP Ø TOP	Ø INF Ø BOTTOM
<b>D 145</b>	134	40	17	22/14
<b>D 146</b>	220	60	24	27/20
<b>D 147</b>	215	69	19	31/24
<b>D 148</b>	137	45	14	22/14

Articoli torniti / Machined items



D.146



D.147



D.145



D.148

# D



D.103



D.105

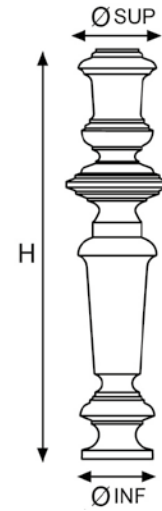

D.104

ARTICOLO ITEM	L	H	Ø SUP Ø TOP	Ø INF Ø BOTTOM
<b>D 103</b>	76	260	26	80
<b>D 104</b>	80	185	65	80
<b>D 105</b>	72	290	25	50/45

Articoli torniti / Machined items



D.106



D.107

ARTICOLO ITEM	L	H	Ø SUP Ø TOP	Ø INF Ø BOTTOM
<b>D 106</b>	85	320	32	59/54
<b>D 107</b>	90	310	27	60/54

Articoli torniti / Machined items

# D



D.122



D.124



D.125



D.123

ARTICOLO ITEM	H	Ø MAX	FILETTO THREAD
<b>D 122</b>	185	130	10x1
<b>D 123 SM</b>	185	135	10x1
<b>D 124</b>	285	175	10x1
<b>D 125 SM</b>	285	180	10x1

Articoli torniti o smerigliati / Machined or linnished items



D.132



D.134SM



D.135

ARTICOLO ITEM	L	H	Ø SUP Ø TOP	Ø INF Ø BOTTOM
<b>D 132</b>	79	285	28	79
<b>D 134 SM</b>	122	245	29	65/56
<b>D 135</b>	89	46	65	89

Articoli torniti / Machined items



# D



D.109SM



D.127SM



D.128SM

ARTICOLO ITEM	Ø MAX	H	Ø SUPE Ø TOP	Ø INF Ø BOTTOM
<b>D 109SM</b>	79	250	20	56/48
<b>D 127SM</b>	50	220	20	26/20
<b>D 128SM</b>	34	147	16	20/15

Articoli torniti e smerigliati / Machined and linnished items



D.131



D.143



D.142



D.144

ARTICOLO ITEM	Ø MAX	H	FILETTO THREAD
<b>D 131</b>	150	275	10x1
<b>D 142</b>	150	170	10x1
<b>D 143</b>	150	235	10x1
<b>D 144</b>	205	310	10x1

Articoli torniti e smerigliati  
Machined and linnished items

# D



D.149



D.150



D.199



D.155



D.156

ARTICOLO ITEM	H	L	Ø SUP Ø TOP	Ø INF Ø BOTTOM	
<b>D 149</b>	175	60	21	60	
<b>D 150</b>	156	80	26	80	
<b>D 155</b>	140	32	18	18	
<b>D 156</b>	183	36	18	18	
<b>D 199 (*)</b>	150	51	20	51	10x1

(\*) Not available for USA market  
 Articoli torniti / Machined items



ARTICOLO ITEM	H	L	Ø SUP Ø TOP	Ø INF Ø BOTTOM
<b>D 151</b>	185	55	20	22
<b>D 152</b>	285	70	20	30
<b>D 153</b>	260	70	21	24
<b>D 154</b>	200	70	21	24

Articoli in due metà / In two halves



D.151



D.152



D.153



D.154



D.172



D.173



D.170



D.169

ARTICOLO ITEM	H	L	Ø SUP Ø TOP	Ø INF Ø BOTTOM	FORO/FILETTO HOLE/THREAD
<b>D 169*</b>	155	33	14	14	n.2 10x1
<b>D 170*</b>	215	43	15	16	10,5
<b>D 172 torn.</b>	155	30	17	25	n.2 10x1
<b>D 173 torn.</b>	230	40	23	30	10,5

\*In due pezzi saldati tra loro

\*Two halves solded



D.203



D.202



D.204 (-)

ARTICOLO ITEM		H	Ø MAX	Ø SUP./INF.
D 202	Torn.	148	45	25-21
D 203	Torn.	195	55	30-27
D 204 (-)	Torn.	120	65	25-31

(-) Not available for USA market

# D



D.171



D.157



D.158



D.183



E.133



E.126



E.127



E.134

ARTICOLO ITEM	H	L	Ø SUP Ø TOP	Ø INF Ø BOTTOM
<b>D 157</b>	250	63	42	60
<b>D 158</b>	178	49	32	49
<b>D 171</b>	330	80	52	80
<b>D 183</b>	145	40	26	40
<b>E 126</b>	20	80	50	80
<b>E 127</b>	20	100	60	100
<b>E 133</b>	15	60	40	60
<b>E 134</b>	25	140	80	140

ARTICOLO ITEM	H	L	Ø SUP Ø TOP	Ø INF Ø BOTTOM
<b>D 165</b>	200	50	50	30
<b>D 181</b>	120	30	30	20
<b>D 182</b>	160	40	40	25



D.165



D.182



D.181



Z.268



Z.267



Z.266

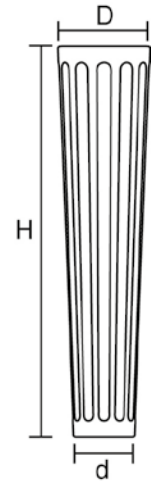

D.181

Z.215 IMP

Z.293C



D.182

Z.200-41

Z.294C



D.165

Z.284C

Z.201-50



ARTICOLO ITEM	H	Ø SUP. Ø TOP	Ø INF. Ø BOTTOM	FILETTO THREAD
<b>D 195</b>	190	13	110	n°1 10x1
<b>D 196</b>	260	15	140	n°1 10x1
<b>D 197</b>	350	16	185	n°1 10x1

Vedi anche articolo 0.258 a pag. 369 / See also item 0.258 on page n. 369



D.195

D.196



D.197

4015



4014



ARTICOLO ITEM		H	Ø	
L 88	PASS	14	80	
L 89	PASS	18	110	
4014			150	Vetro Opale
4015			200	Vetro Opale

ARTICOLO ITEM	H	LATO SUP. SIDE TOP	LATO INF. SIDE BOTTOM	
D 188	SM	160	30	21
D 189	SM	220	40	30
D 190	SM	300	50	40

Con disco di copertura / Supplied with cover disc



D.188



D.189



D.190

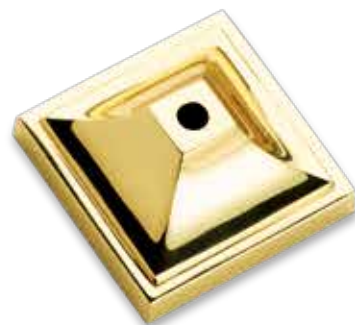

0.208  
0.208 FOR

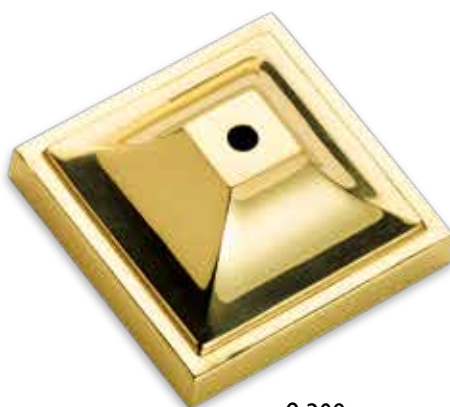

0.209  
0.209 FOR



0.210  
0.210 FOR

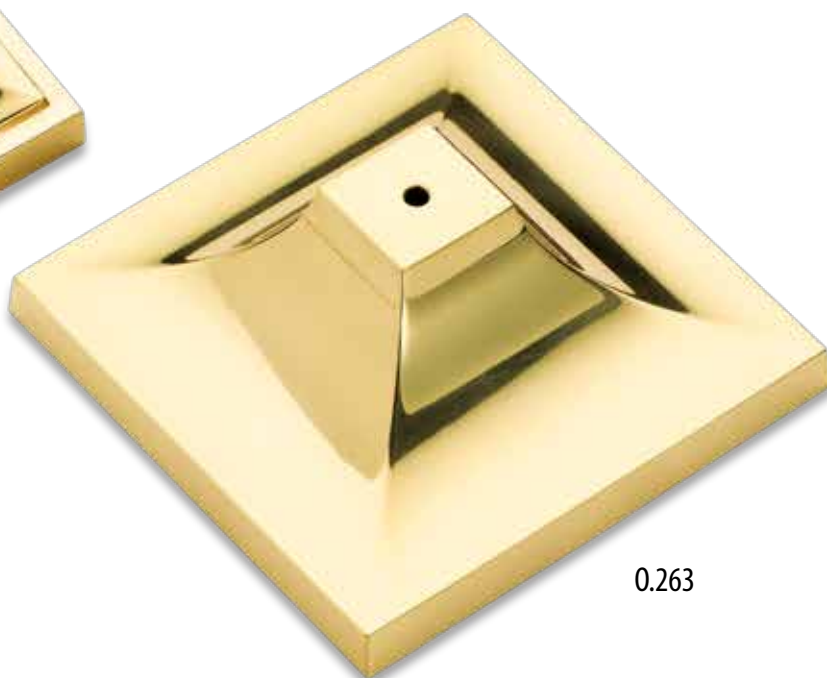

0.263

ARTICOLO ITEM	H	LATO SIDE
0 208	38	83
0 208 FOR*	38	83
0 209	50	110
0 209 FOR*	50	110
0 210	57	140
0 210 FOR*	57	140
0 263	82	220

\* Con fori laterali + staffa fil. M4  
With bracket and two side holes



D.213SM



D.214SM

ARTICOLO ITEM		LATO SIDE	H	FILETTO THREAD
<b>D 213</b>	SM	110	220	10x1
<b>D 214</b>	SM	160	300	10x1

Articoli torniti e smerigliati / Machined and linnished items

# D

ARTICOLO ITEM	H	Ø MAX	Ø BASE	FILETTO THREAD
<b>D 207</b> Torn	195	100	85	13x1 (*)
<b>D 208</b> Torn	270	135	110	13x1 (*)
<b>D 209</b> Torn	340	170	150	13x1 (*)

(\*) Forniti con riduzione 13x1 / 10x1  
 Supplied with reducer 13x1 / 10x1



D.209



D.208



D.207

ARTICOLO ITEM	H	Ø MAX	Ø BASE	FILETTO THREAD
<b>D 210</b> Torn	195	110	85	10x1
<b>D 211</b> Torn	270	140	125	13x1 (*)
<b>D 212</b> Torn	340	180	160	13x1 (*)

(\*) Forniti con riduzione 13x1 / 10x1  
 Supplied with reducer 13x1 / 10x1



D.212



D.210



D.211

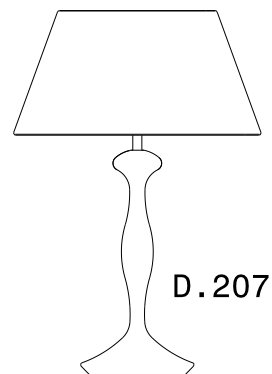
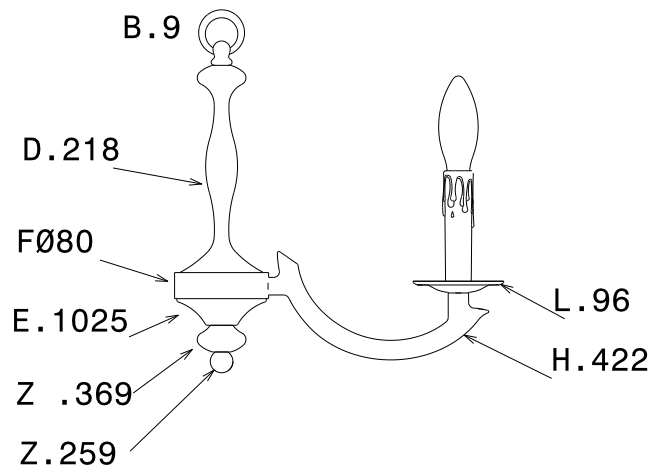
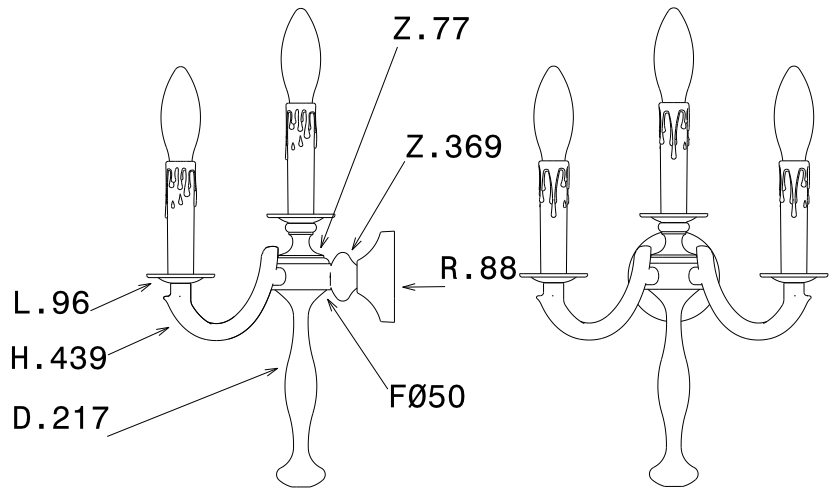
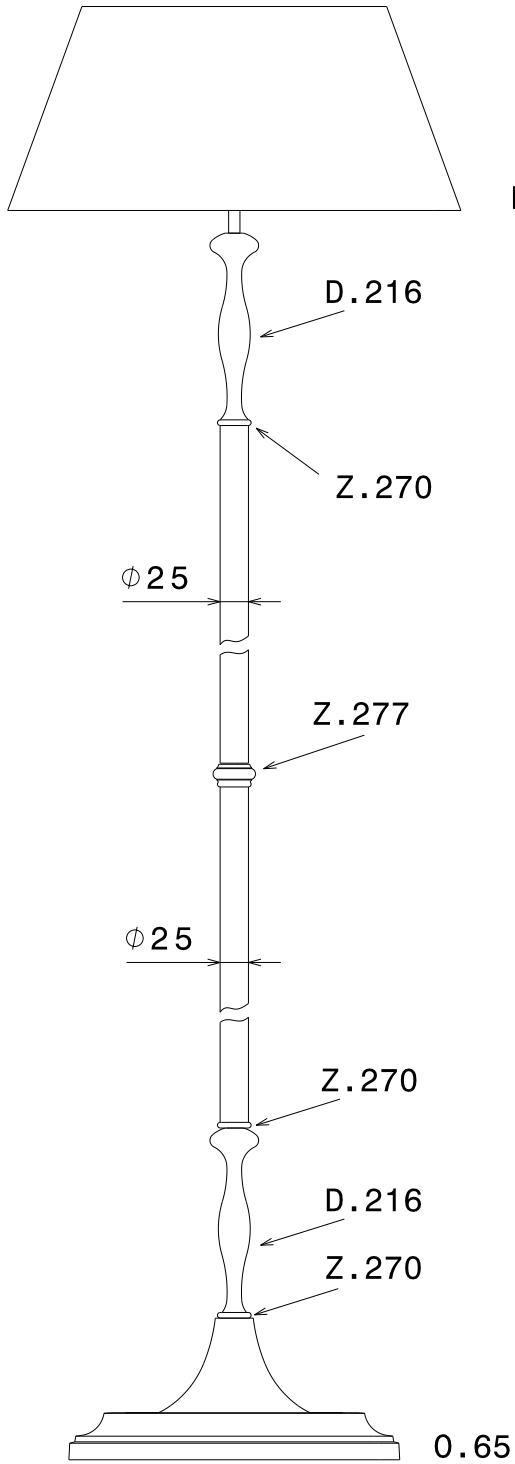

ARTICOLO ITEM	H	Ø TOP	Ø MAX	Ø BOTTOM	FORO/FILETTO HOLE/THREAD
<b>D 215</b> Torn	142	20	30	25	10,2
<b>D 216</b> Torn	165	=	43	25	13x1 (*)
<b>D 217</b> Torn	175	=	43	50	13x1 (*)
<b>D 218</b> Torn	185	=	43	80	13x1 (*)
<b>D 219</b> Torn	258	=	56	120	13x1 (*)
<b>Z 259</b> Torn	18	=	20	=	10x1
<b>Z 369</b> Torn	23	16	43	=	10,2

(\*) Forniti con riduzione 13x1 / 10x1 / Supplied with reducer 13x1 / 10x1



D.217

D.216

D.215

D.218

D.219

Z.369

Z.259



# D



D.200



D.201

ARTICOLO ITEM	H	Ø SUP. Ø TOP	Ø INF. Ø BOTTOM
<b>D 200</b> Torn.	260	100/95	140
<b>D 201</b> Torn.	350	130/125	190
<b>D 200 B</b>		3,2	93
<b>D 201 B</b>		3,2	123



**GHIDINI**  
GIUSEPPE BOSCO

# D

ARTICOLO ITEM	H	Ø MAX	Ø INF. Ø BOTTOM	Ø IMP. SUP Ø COUNT. TOP	FORO HOLE
<b>D 220</b>	65	70	35	50	10,5
<b>D 220/B</b>	48	70	28	50	15
<b>D 221</b>	120	58	50	15	10,5
<b>D 222</b>	90	90	40	60	13,5
<b>D 222/B</b>	65	90	33	60	15
<b>D 223</b>	168	68	60	15	10,5



D.221



D.223



D.220



D.222



D.220/B



D.222/B

ARTICOLO ITEM	H	Ø MAX	Ø INF. Ø BOTTOM	Ø IMP. SUP Ø COUNT. TOP	FOR HOLE
<b>D 224</b>	69	58	30	50	10,5
<b>D 224/B</b>	48	58	25	50	15
<b>D 225</b>	110	50	50	15	10,5
<b>D 226</b>	93	70	35	60	15
<b>D 226/B</b>	65	70	30	60	18
<b>D 227</b>	154	60	60	20	10,5



D.227



D.225



D.226



D.224



D.226/B



D.224/B



D.227

D.222/B



D.223

D.226/B



D.225

D.220/B



D.221

D.224/B

D.227



D.223



D.226

D.222

D.225



D.221



D.224

D.220



D.233



D.235



D.232



D.234



D.239



D.237



D.238



D.236



D.233

D.232



D.235

D.234



D.237

D.236



D.239

D.238

ARTICOLO ITEM	H	ØMAX.	ØINF. BOTTOM	ØIMP. SUP. ØCOUNT. TOP	FORO HOLE
D 232	69	85	60	80	10,5
D 233	126	80	80		10,5
D 234	95	100,5	80	91	10,5
D 235	166	90	90		10,5
D 236	70	82	60	70	10,5
D 237	123	70	70		10,5
D 238	96	106	80	90	10,5
D 239	165	90	90		10,5



# D

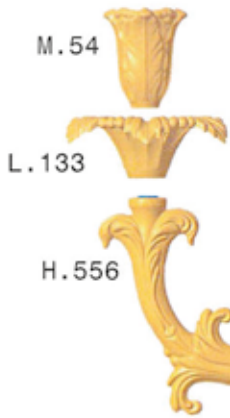
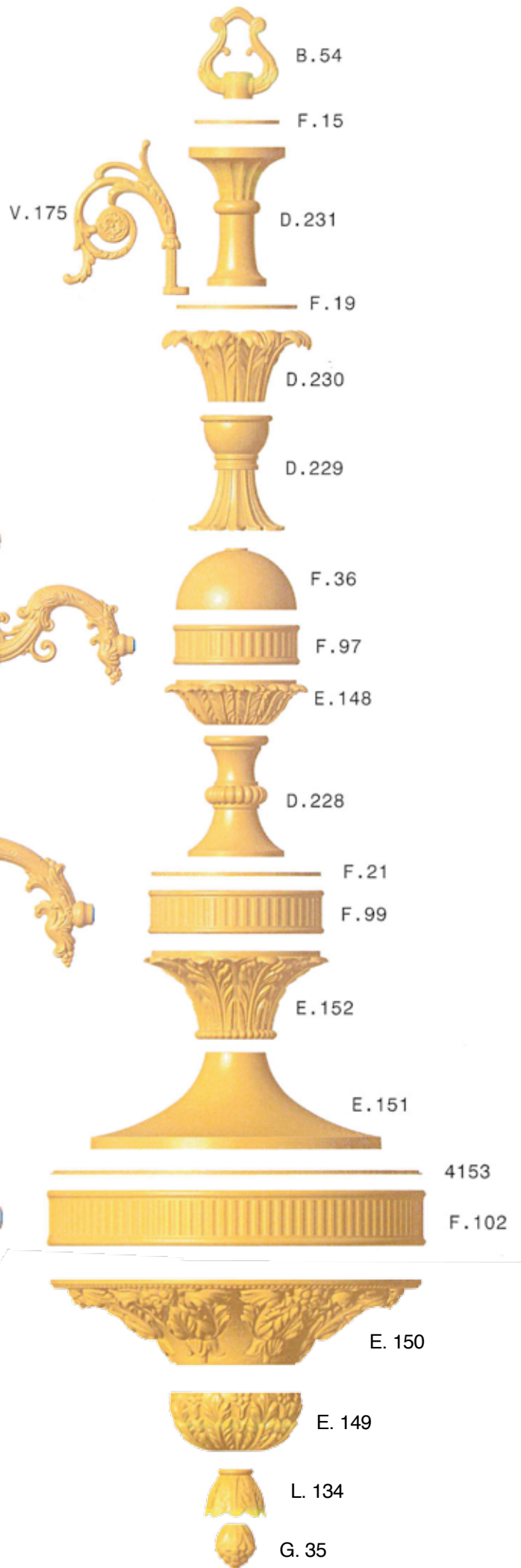



D.228

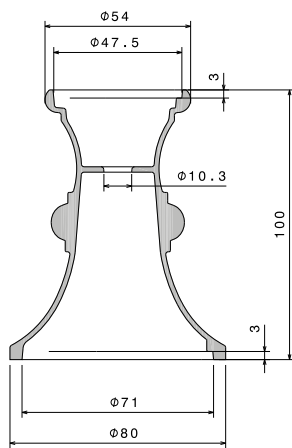

D. 228

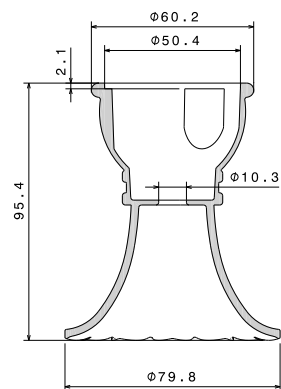

D. 229



D.229

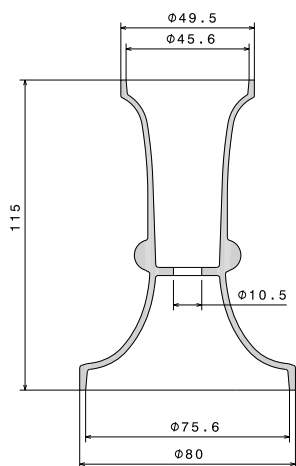

D. 231



D.231

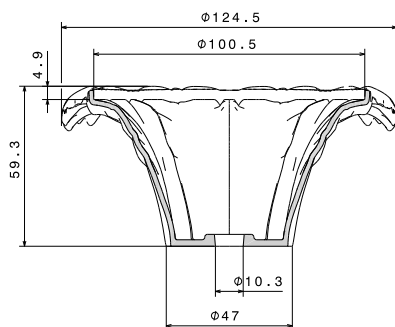

D. 230



D.230

ARTICOLO ITEM	H	ØMAX.	ØINF. BOTTOM	ØIMP. SUP. ØCOUNT. TOP	FORO HOLE
D 228	100	80	80	47,5	10,3
D 229	95	80	80	50	10,3
D 230	59	125	47	100	10,3
D 231	115	80	80	45/50	10,5

# D



D.241

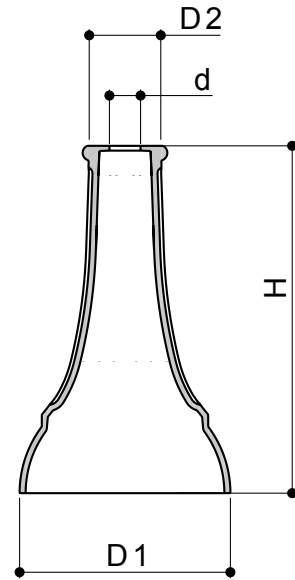

D.240

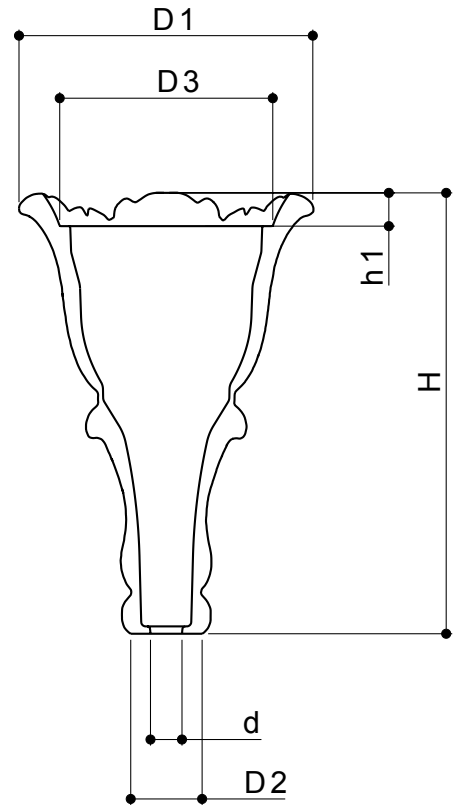

ARTICOLO ITEM	D1	D2	D3	H	H1	D
<b>D 240</b> (*)	97,5	24	70,5	146	11	10,2
<b>D 241</b> (*)	69,7	24	-	115	-	10,2

(\*) Not available for USA market



**GHIDINI**  
GIUSEPPE BOSCO





D.1001



D.1034



D.1007



D.1035



D.1003



D.1010



E.1001

F.48

D.1035

ARTICOLO ITEM	H	L	Ø SUP Ø TOP	Ø INF Ø BOTTOM
<b>D 1001</b>	118	120	120/110	20
<b>D 1003</b>	160	100	45/38	100
<b>D 1007</b>	117	130	130/110	60/56
<b>D 1010</b>	132	114	26	114/100
<b>D 1034</b>	80	80	80	20

Bronze véritable

ARTICOLO ITEM	H	Ø MAX	Ø INF. Ø BOTTOM	Ø IMP. SUP Ø COUNT. TOP	FORO HOLE
<b>D 1035 (*)</b>	111	140	140	50	10,5
<b>F 48</b>	22	140	110	50	10,5
<b>E 1001</b>	60	110	25	15	10,5



ARTICOLO ITEM	H	Ø
<b>D 1001 + E 1001</b>	175	120
<b>D 1034 + E 1032</b>	130	80
<b>D 1003 + Z1001 + E 1004</b>	210	110
<b>D 1007 + E 1018 + E 1020</b>	175	130
<b>D 1010 + E 1026</b>	160	114

Bronze véritable

E.1004



E.1018

ARTICOLO ITEM	H	L	Ø SUP Ø TOP	Ø INF Ø BOTTOM
<b>D 1002</b>	200	60	50	32
<b>D 1017</b>	180	62	22	30/23
<b>D 1018</b>	195	50	21	24

Articoli in due metà / Two halves items  
Bronze véritable



D.1002



D.1017

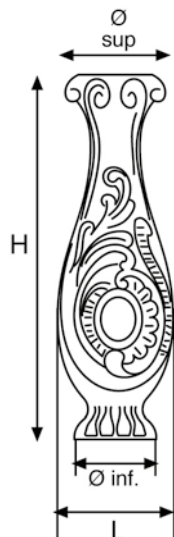

D.1018



ARTICOLO ITEM	H	L	Ø SUP Ø TOP	Ø INF Ø BOTTOM
<b>D 1008A</b>	130	90	60	90
<b>D 1008B</b>	91	97	97/90	31
<b>D 1015</b>	127	75	21	75
<b>D 1016</b>	50	87	87/76	32



# D



Z.1076



D.1025

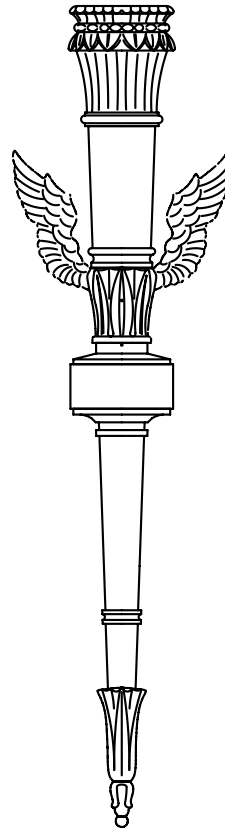

H cm 41,5



D.1023



G.1006



D.1024

ARTICOLO ITEM	H	L	Ø SUP	Ø INF Ø TOP	FILETTO Ø BOTTOM	THREAD
<b>D 1023</b>	144	50	50	15	10x1	
<b>D 1024</b>		95	110	32	27,5	
<b>D 1025</b>	74	35	34	32		
<b>F Ø50</b>		22	52	50	50	10x1
<b>G 1006</b>		24	70			10x1
<b>Z 239</b>		12	50	26	50	
<b>Z 1076*</b>	62	55	47	30,5		

\* Con disco di copertura / supplied with cover F.76  
Bronze véritable



F.Ø50



Z.239



D.1026

D.1026

M.31



M.31



F.76 Ø47



D.1037

D.1036

D.1027

ARTICOLO ITEM	H	L	Ø SUP Ø TOP	Ø INF Ø BOTTOM
<b>F 76</b>	2,8	-	47	47
<b>D 1026(*)</b>	186	55	55/47	28/25
<b>D 1027(*)</b>	241	55	55/47	25
<b>M 31</b>	55	31	31/25	25

(\*) Con disco di copertura / Supplied with cover F.76

Not available for USA market

Bronze véritable

ARTICOLO ITEM	H	Ø MAX	Ø INF. Ø BOTTOM	Ø IMP. SUP Ø COUNT. TOP	FORO HOLE
<b>D 1036 (*)</b>	135	38	16	30	10,5
<b>D 1037 (*)</b>	180	41	21	30	10,5

(\*) Fornito con disco di copertura / Supplied with cover disc

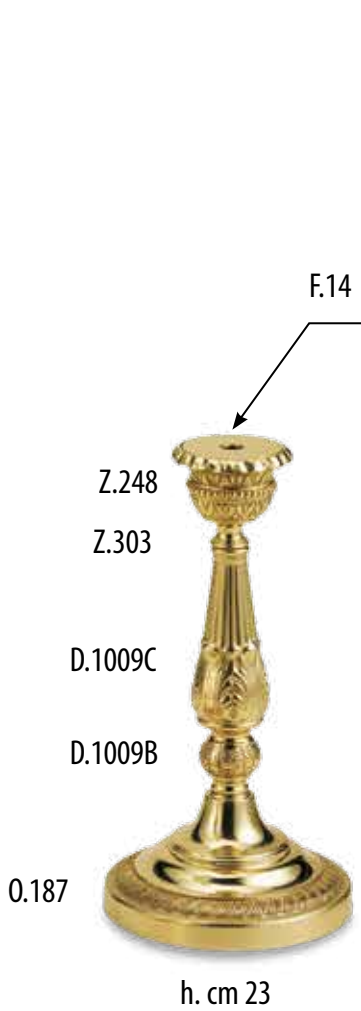

ARTICOLO ITEM	H	Ø MAX	Ø SUP. Ø TOP	Ø INF. Ø BOTTOM
D 1009 A	105	40	13	31-33
D 1009 B	40	32	25-29	20
D 1009 C	93	40	19	31-33
D 1028	160	52	27	40-46
D 1029	63	47	35-40	25

Bronze véritable



D.1014



D.1013



D.1031



D.1030



D.1033



D.1032

ARTICOLO ITEM	H	Ø MAX	Ø SUP. Ø TOP	Ø INF. Ø BOTTOM
<b>D 1013</b>	116	57	51-57	20
<b>D 1014</b> Torn.	29	50	18	50
<b>D 1030</b>	138	67	61-67	23
<b>D 1031</b> Torn.	34	60	20	60
<b>D 1032</b>	180	85	80-85	25
<b>D 1033</b> Torn.	42	80	22	80

Bronze véritable